

ELVORON LULA

LIMITED USE LIMITED APPLICATION ELEVATOR



The Elvora LULA elevator is designed to service low rise and low occupancy commercial spaces. It is fully automatic and is very similar in look and feel to larger commercial elevators. The Elvora LULA provides vertical transportation for everyone, including able-bodied passengers, people with disabilities and even children in strollers.

DRIVE SYSTEM

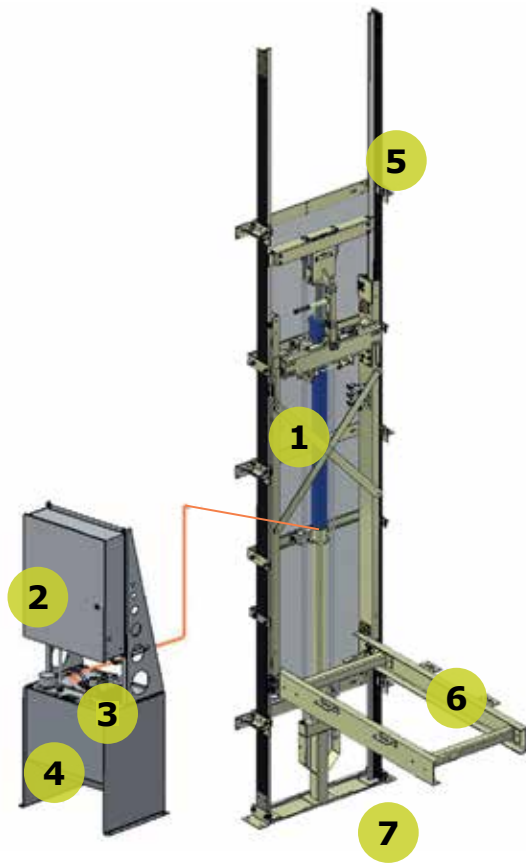

- 1** 1:2 Cable hydraulic drive with automatic leveling, emergency manual lowering and instantaneous safety brake system
- 2** Computerized (PLC) controller has an emergency backup power system for lowering in the event of power failure.
- 3** Two-speed hydraulic control valve provides smooth, comfortable starting and stopping.
- 4** Submersed hydraulic pump and motor ensures quiet operation.
- 5** Sturdy 8 lbs per foot elevator guide rail system ensures a smooth, quiet ride
- 6** Heavy duty cantilevered car support sling provides capacity of up to 1,400 lbs (635 kg).
- 7** Minimum pit depth is 14" (356 mm).

SPECIFICATIONS

Rated Load: 1,400 lbs (635 kg)

Speed: Standard 30 fpm (0.15 m/s) nominal speed | Option 40 fpm (0.2 m/s), contact Garaventa Lift

Travel Range: Standard: 25 ft (7.6 meters) For greater travel distances, contact Garaventa Lift

Overhead Clearance (Refuge Space): 135" (3429mm) | 114" (2896mm) with car top prop

Drive System: 1:2 Cable Hydraulic | Heavy duty car sling with roller guide shoes running on 8 lb. per foot steel T-Rails | Quiet submersed pump and motor | Factory pre-set and tested 2-speed valve for smooth start and stop.

Controls: Fully automatic push button operation | Garaventa-Design PLC Controller | Integrated self-diagnostics | Digital floor indicator in car | Automatic car lighting upon entry | Illuminated push buttons

Power Supply: Elevator: Standard 208 VAC three phase | Option 230 VAC single phase | Lighting: 110 VAC single phase, 15 amps

Doors: 36" x 80" (914mm x 2032mm) two-speed horizontal sliding hoistway and car doors

Safety Features: Emergency battery lowering system | Emergency manual lowering valve | Safety brake system Automatic bi-directional floor levelling | Stop keyswitch and alarm button in car | Final limit switch | Overspeed valve | Pit Prop

Unique Standard Features: Braille markings | Car direction lantern comes with audio and visual signals | Full height photo-electric door sensors

Code Compliance: ASME A17.1/CSA B-44 | Section 5.2 LU/LA Elevators. ADA (Americans with Disabilities Act)

Popular Options: Integrated hands free telephone | Phone Monitoring | Custom car finishes | Additional handrails | Buffer springs (increases your pit depth)

Warranty: 2 year standard warranty | Optional additional 5 year extended warranty (7 years)

FINISHES

Car Operating Panels



The Elvora LULA control panel is equipped with a digital floor indicator, illuminated floor buttons, alarm button, door open and close buttons and a keyed emergency stop switch. An optional hands-free phone is available.

Car Direction Lantern



Mounted in the car doorway, the Car Direction Lantern is an audio and visual signaling device that indicates direction of travel and arrival at the floor.

Hall Stations



The wall plates and the push buttons are both brushed stainless steel for maximum durability. The push button features an illuminated border to indicate that the elevator has been called.

Lighting



Four recessed low-voltage L.E.D. light fixtures illuminate automatically when the door is opened. Available in white or black. Optional in chrome.

Handrails



Offered in brushed stainless steel, the handrail is located on the control wall. Additional handrails can be mounted for extra passenger safety.

Keyed Hall Station



For increased safety and security, an optional key switch allows the entire elevator to be deactivated. Key switches can be custom designed to deactivate only certain hall stations or to control access to certain floors. Brushed stainless steel finish.

Design Assistance



www.garaventlift.com



Design Hotline: 1.800.663.6556 Toll Free North America

ENTRY & EXIT CONFIGURATIONS

Warning about LULA Elevators: Local code authorities may have a limit on travel, capacity, car sizes and speed. Contact your local Garaventa Lift representatives before starting your project.

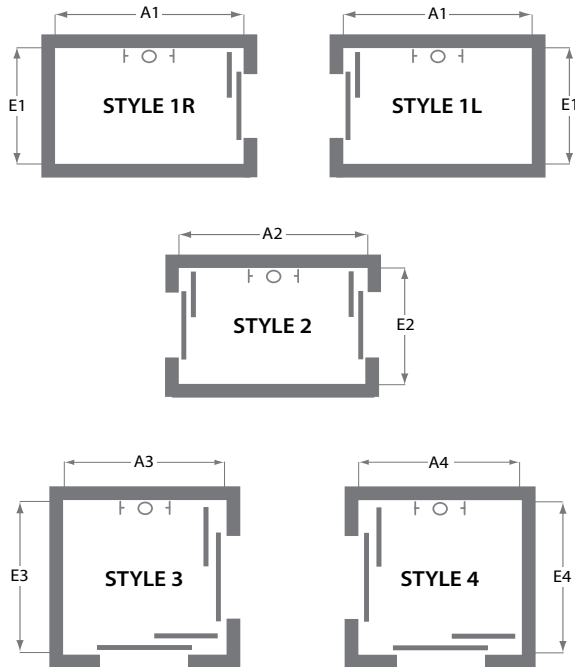

WALL FINISHES

Laminate



Car Wall Trim Colors



HOISTWAY DIMENSIONS

Car Size	E1	A1	E2	A2	E3	A3	E4	A4
48" X 54" (1220 X 1372)	69"* (1753)	73" (1854)	69"* (1753)	81-1/2" (2070)				
42" X 60" (1067 X 1524)	69"* (1753)	79" (2007)	69"* (1753)	87-1/2" (2223)				
51" X 51" (1295 X 1295)					78-3/4" (1975)	72" (1829)	78-3/4" (1975)	72" (1829)

*66" (1676) hoistway width may be feasible. Consult with your local Garaventa Lift Representatives.



Contact us today:

(800) 663-6556 | garaventlift.com

© Garaventa Lift. As we are continuously improving our products, specifications outlined in this brochure are subject to change without notice. Due to the nature of the printing process, colors shown in the brochure may not be an accurate representation of the actual product.